

THOMSIT

make it!



**AS GOOD AS
A NEW SCREED?
THE EASY WAY!**

Safe refurbishment of damaged old screeds

www.thomsit.com

EASY RENOVATION
WITH A

SYSTEM !



Easy, safe refurbishment of damaged old screeds

You are working on the renovation of an old floor and see a catastrophe in front of you. The screed is damaged, with a spider's web of cracks running across its surface and some more severe cracks. The surface is also crumbly and sandy. Your spontaneous reaction is that a new screed needs to be laid!

We have an alternative for you! You can save the floor with the appropriate THOMSIT renovation system!



Substrate preparation The renovation system in use

Grind the surface and remove any layers which could impair adhesion. Then apply **THOMSIT R 766** to the entire surface which has been treated.

TIP: THOMSIT-FLOOR® renovation underlays are mainly used separately, but they can also be combined. Our recommendation is to use **THOMSIT-FLOOR® TF 320** for wide cracks and **THOMSIT-FLOOR® TF 310** for fine cracks.

For wide cracks:

- 1 Level the surface along the crack and 30 cm on both sides evenly with **THOMSIT R 790**.
- 2 30 cm of the glass fibers should protrude on each side of the crack. Press **THOMSIT-FLOOR® TF 320** into position over the entire surface using a smoothing trowel so that it is evenly bedded in the leveling compound.

For fine cracks:

- 3 Unroll **THOMSIT-FLOOR® TF 310** glass fiber mat, cut to size and lay the strips loosely on the prepared substrate with an overlap of about 1 – 2 cm. Also use THOMSIT TRD 5 edge insulating strips for the wall/floor transition.
- 4 In the case of critical substrates, we recommend the use of a fiber-reinforced leveling compound (**THOMSIT AS 2** or **THOMSIT FA 97**). Pour the leveling compound onto the **THOMSIT-FLOOR® TF 310 glass fiber mat**, distribute it with a minimum layer thickness of 5 mm using a smoothing trowel (do not use a squeegee) and de-aerate it carefully using a spiked roller.

You will find further information on processing and consumption in the latest technical data sheets at **www.thomsit.com**.

Do you need more support? Just contact your local THOMSIT adviser.



SYSTEMATIC RENOVATION

Do it the easy way with perfectly harmonized THOMSIT products!

THOMSIT R 766 is recommended for substrate preparation. For the rehabilitation of severely cracked screed, we recommend THOMSIT R 790, THOMSIT-FLOOR® TF 320 and THOMSIT-FLOOR® TF 310 for strength enhancement and reinforcement.

- 1 **THOMSIT R 766 multi-purpose primer** concentrated primer as a bonding slurry for THOMSIT leveling compounds



- 2 **THOMSIT R 790 filling primer** for the renovation of old substrates with a large number of joints



- 3 **THOMSIT-FLOOR® TF 320 glass fiber strips** for bridging cracks up to 5 mm



- 4 **THOMSIT-FLOOR® TF 310 glass fiber mat** for repairing cracks up to 3 mm



- 5 **THOMSIT AS 2 fiber-anhydrite leveling compound** for leveling layers of 3 – 30 mm in a single step. As an alternative, we recommend cement-based **THOMSIT FA 97**

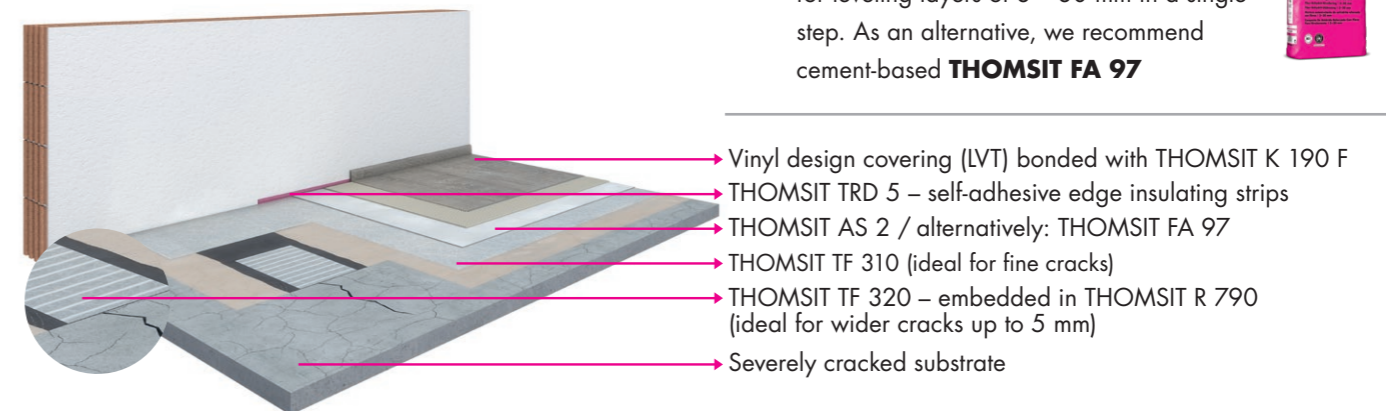
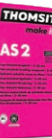

ONE SYSTEM – MANY BENEFITS



Cost-effective and resource-saving –

It is not necessary to remove and dispose of the old screed. This approach not only saves time and cost, but also reduces waste volumes and makes for environmentally compatible renovation.



Saves time and labor cost –

The renovation system allows the surface to be used again within 3 – 4 working days (instead of several weeks).



Health and safety standards meet the highest requirements. No epoxy resin required – simple and safe to use thanks to product system with glass fiber technology.



Reliable rehabilitation system on heated floor structures: cracks no longer need to be cut out – prevents possible damage to water pipes in floor.



Compared with other renovation solutions, the THOMSIT renovation system really is the easy way for you. Instead of installing a new screed, you can simply repair the old floor. That is not only cost effective, but also environmentally compatible and safe as well as saving time.

THOMSIT

make it!

PCI Augsburg GmbH

Piccardstraße 11

86159 Augsburg

Phone +49 821 5901-0

thomsit-info@pci-group.eu

www.thomsit.com

Your competent partner for flooring technology